

Bills of Material:

NO.	ITEM#	MATERIAL	QTY	UNIT	TOTLE	TYPE	ASSY
			WEIGHT				
5	REMOVABLE-SHELF-31N		2			ASSEMBLY	1
4	7704		8			PART	1
3	303FU-10		2			PART	1
2	PULL-FRAME-3X42		1			ASSEMBLY	1
1	MOUNT-FRAME-3X42		1			ASSEMBLY	1

<b>HARDWARE</b> <b>HR</b> RESOURCES PROPRIETARY AND CONFIDENTIAL THE INFORMATION CONTAINED IN THIS DRAWING IS THE SOLE PROPERTY OF HARDWARE RESOURCES INC. ANY REPRODUCTION IN PART OR AS A WHOLE WITHOUT THE WRITTEN PERMISSION OF HARDWARE RESOURCES INC. IS PROHIBITED.	4319 MARLENA ST. BOSSIER CITY, LA71111	ITEM#: WFPO342	MATERIAL:  WEIGHT: 9
	FINISH:  PROJECTION:	TOLERANCE UNLESS OTHERWISE SPECIFIED: X : MM ±0.20 X X : MM ±0.10 X X X : MM ±0.05 ANGULAR: ±0.5° DO NOT SCALE DRAWING	UNIT: SIZE: DRAWN BY: <i>alan.liu</i> CHECKED BY: APPROVED BY:

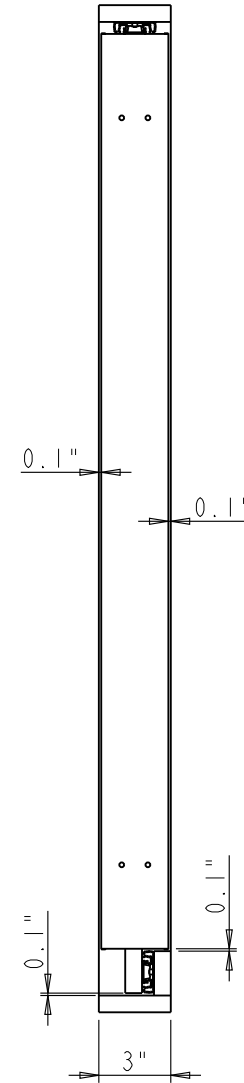
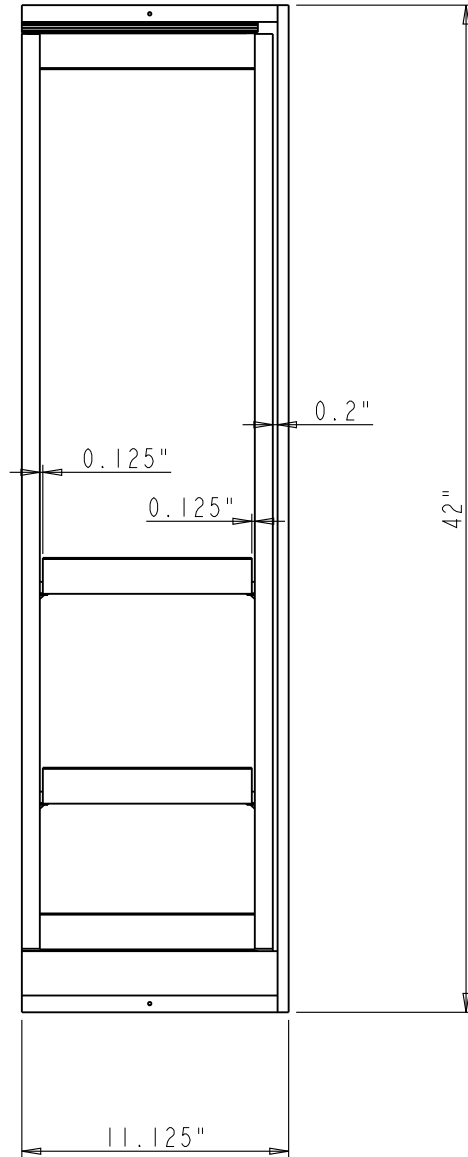

<b>HARDWARE</b> <b>HR</b> 4319 MARLENA ST. BOSSIER CITY, LA71111 <b>RESOURCES</b> <u>PROPRIETARY AND CONFIDENTIAL</u> THE INFORMATION CONTAINED IN THIS DRAWING IS THE SOLE PROPERTY OF HARDWARE RESOURCES INC. ANY REPRODUCTION IN PART OR AS A WHOLE WITHOUT THE WRITTEN PERMISSION OF HARDWARE RESOURCES INC. IS PROHIBITED	<b>ITEM#:</b> WFPO342	<b>MATERIAL:</b>
	<b>FINISH:</b>	<b>WEIGHT:</b> 9
<b>TOLERANCE UNLESS OTHERWISE SPECIFIED:</b> X : MM ±0.20 X.X : MM ±0.10 X.XX : MM ±0.05 ANGULAR: ±0.5° DO NOT SCALE DRAWING	<b>UNIT:</b>	<b>DRAWN BY:</b> <i>alan.liu</i>
<b>SIZE:</b>	<b>CHECKED BY:</b>	<b>DATE:</b>
<b>APPROVED BY:</b>	<b>DATE:</b>	<b>PROJECTION:</b> 

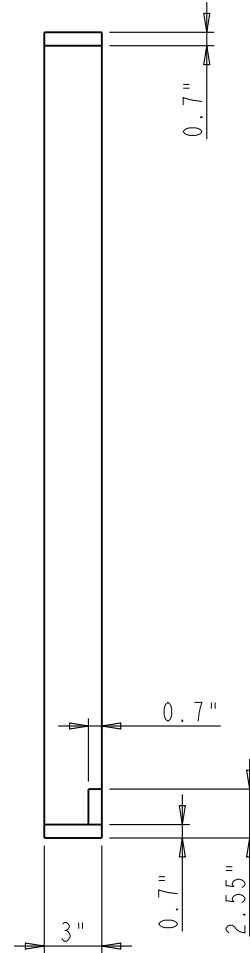
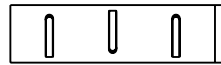
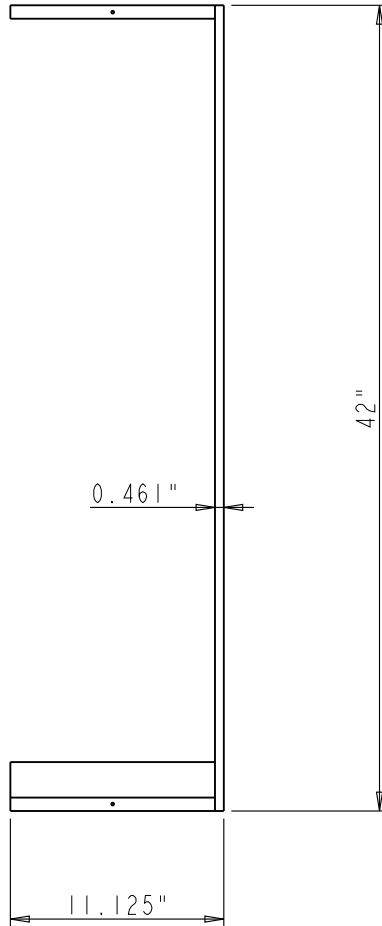
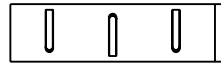

<b>HARDWARE</b> <b>HR</b> 4319 MARLENA ST. BOSSIER CITY, LA 71111 <b>RESOURCES</b> <b>PROPRIETARY AND CONFIDENTIAL</b> THE INFORMATION CONTAINED IN THIS DRAWING IS THE SOLE PROPERTY OF HARDWARE RESOURCES INC. ANY REPRODUCTION IN PART OR AS A WHOLE WITHOUT THE WRITTEN PERMISSION OF HARDWARE RESOURCES INC. IS PROHIBITED	<b>ITEM:</b> MOUNT-FRAME-3X42	<b>MATERIAL:</b> PLY Wood
	<b>FINISH:</b>	<b>WEIGHT:</b> 9
<b>TOLERANCE UNLESS OTHERWISE SPECIFIED:</b> X : MM ±0.20 X.X : MM ±0.10 X.XX : MM ±0.05 ANGULAR: ±0.5° DO NOT SCALE DRAWING	<b>UNIT:</b> <b>SIZE:</b>	<b>PROJECTION:</b> 
<b>DRAWN BY:</b> <i>alan.liu</i>	<b>CHECKED BY:</b>	<b>DATE:</b>
<b>APPROVED BY:</b>		<b>DATE:</b>

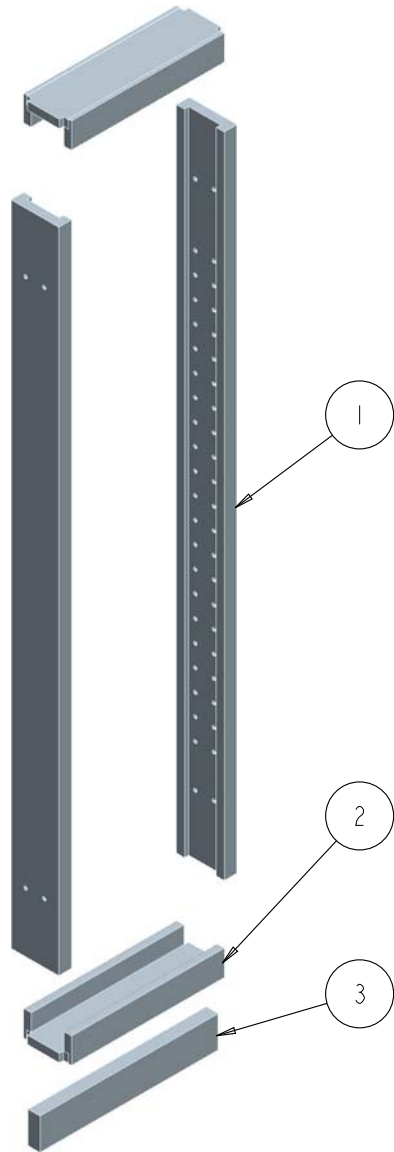

Bills of Material:

3	SLIDER-MOUNT-BOARD_MOVABLE		1			PART	1
2	FIXED-SHELF-3IN		2			ASSEMBLY	1
1	FRONT-BOARD_3X42		2			PART	1
NO.	ITEM#	MATERIAL	QTY	UNIT	TOTLE	TYPE	ASSY LEVEL
				WEIGHT			
<b>HARDWARE</b> <b>HR</b> 4319 MARLENA ST. BOSSIER CITY, LA71111 <b>RESOURCES</b> <u>PROPRIETARY AND CONFIDENTIAL</u> THE INFORMATION CONTAINED IN THIS DRAWING IS THE SOLE PROPERTY OF HARDWARE RESOURCES INC. ANY REPRODUCTION IN PART OR AS A WHOLE WITHOUT THE WRITTEN PERMISSION OF HARDWARE RESOURCES INC. IS PROHIBITED		<b>ITEM#:</b> PULL-FRAME-3X42 <b>FINISH:</b>		<b>MATERIAL:</b> WEIGHT:		<b>PROJECTION:</b> 	
		TOLERANCE UNLESS OTHERWISE SPECIFIED: X : MM ±0.20 X.X : MM ±0.10 X.XX : MM ±0.05 ANGULAR: ±0.5° DO NOT SCALE DRAWING		UNIT: SIZE:	DRAWN BY: <i>alan.liu</i> CHECKED BY:	DATE:	DATE:
				APPROVED BY:		DATE:	DATE:

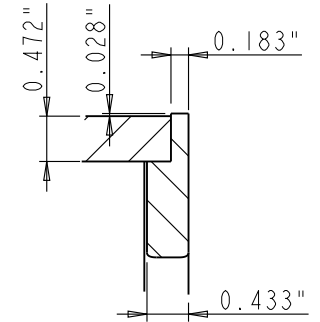
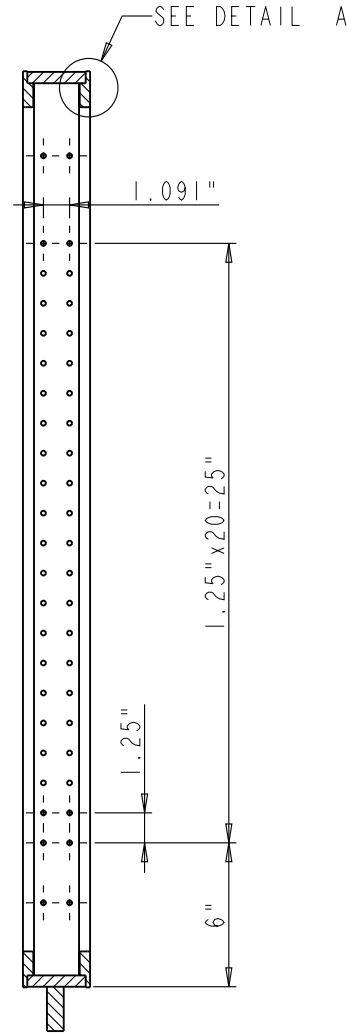
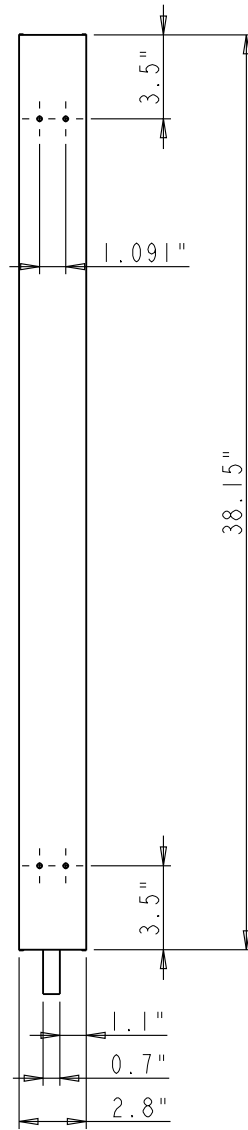
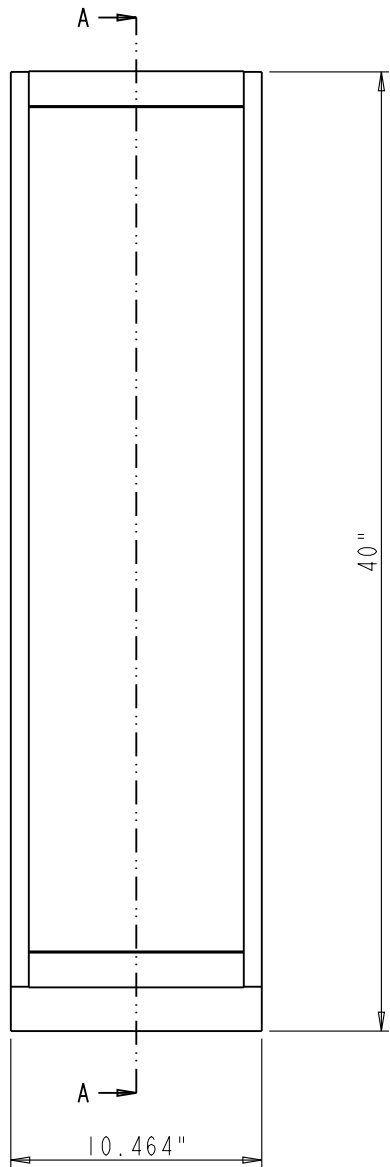

DETAIL A  
SCALE 1:2

SECTION A-A

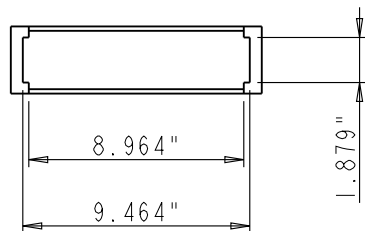

<b>HARDWARE</b> <b>HR</b> 4319 MARLENA ST. BOSSIER CITY, LA 71111 <b>RESOURCES</b> <u>PROPRIETARY AND CONFIDENTIAL</u> THE INFORMATION CONTAINED IN THIS DRAWING IS THE SOLE PROPERTY OF HARDWARE RESOURCES INC. ANY REPRODUCTION IN PART OR AS A WHOLE WITHOUT THE WRITTEN PERMISSION OF HARDWARE RESOURCES INC. IS PROHIBITED.	ITEM: PULL-FRAME-3X42	MATERIAL: WEIGHT: 9
	FINISH:	PROJECTION: 
TOLERANCE UNLESS OTHERWISE SPECIFIED: X: MM ±0.20 XX: MM ±0.10 XXX: MM ±0.05 ANGULAR: ±0.5° DO NOT SCALE DRAWING	UNIT: SIZE:	DRAWN BY: <i>alan.liu</i> CHECKED BY: APPROVED BY:
		DATE:
		DATE:

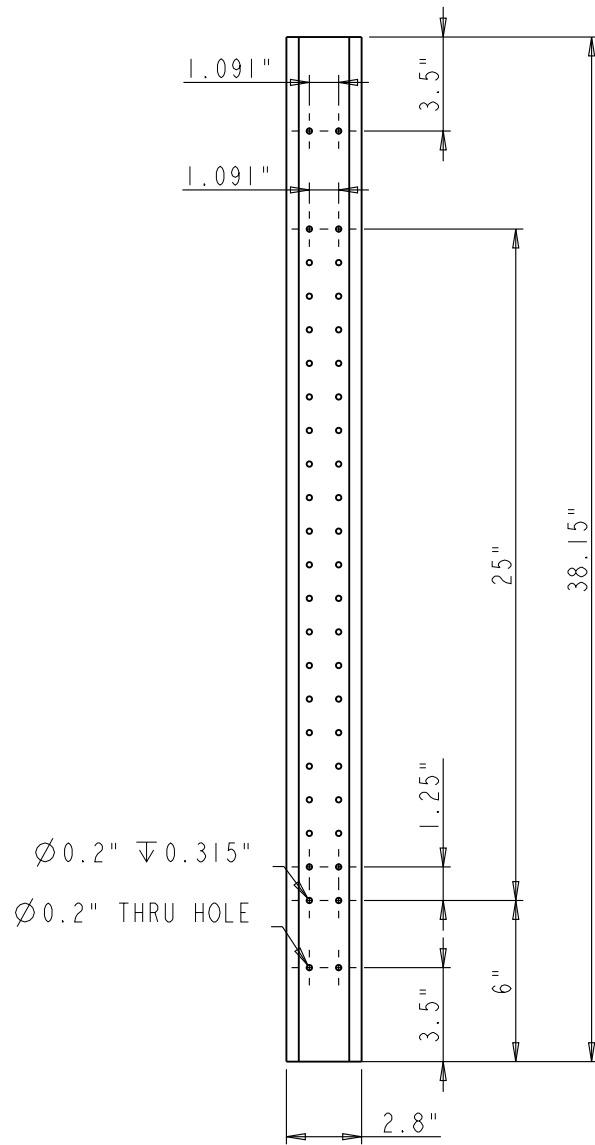

$\varnothing 0.2"$  THRU HOLE  
 $\nabla 0.315"$

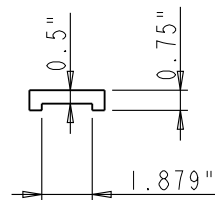

<b>HARDWARE</b> <b>HR</b> 4319 MARLENA ST. BOSSIER CITY, LA 71111 <b>RESOURCES</b>	<b>ITEM:</b> FRONT-BOARD_3X42	<b>MATERIAL:</b> Maple
	<b>FINISH:</b>	<b>WEIGHT:</b> 9
<b>PROPRIETARY AND CONFIDENTIAL</b> THE INFORMATION CONTAINED IN THIS DRAWING IS THE SOLE PROPERTY OF HARDWARE RESOURCES INC. ANY REPRODUCTION IN PART OR AS A WHOLE WITHOUT THE WRITTEN PERMISSION OF HARDWARE RESOURCES INC. IS PROHIBITED.	<b>TOLERANCE UNLESS OTHERWISE SPECIFIED:</b> X : MM $\pm 0.20$ X.X : MM $\pm 0.10$ X.XX : MM $\pm 0.05$ ANGULAR: $\pm 0.5^\circ$ DO NOT SCALE DRAWING	<b>PROJECTION:</b> 
<b>UNIT:</b>	<b>DRAWN BY:</b> <i>alan.liu</i>	<b>DATE:</b>
<b>SIZE:</b>	<b>CHECKED BY:</b>	<b>DATE:</b>
<b>APPROVED BY:</b>		<b>DATE:</b>

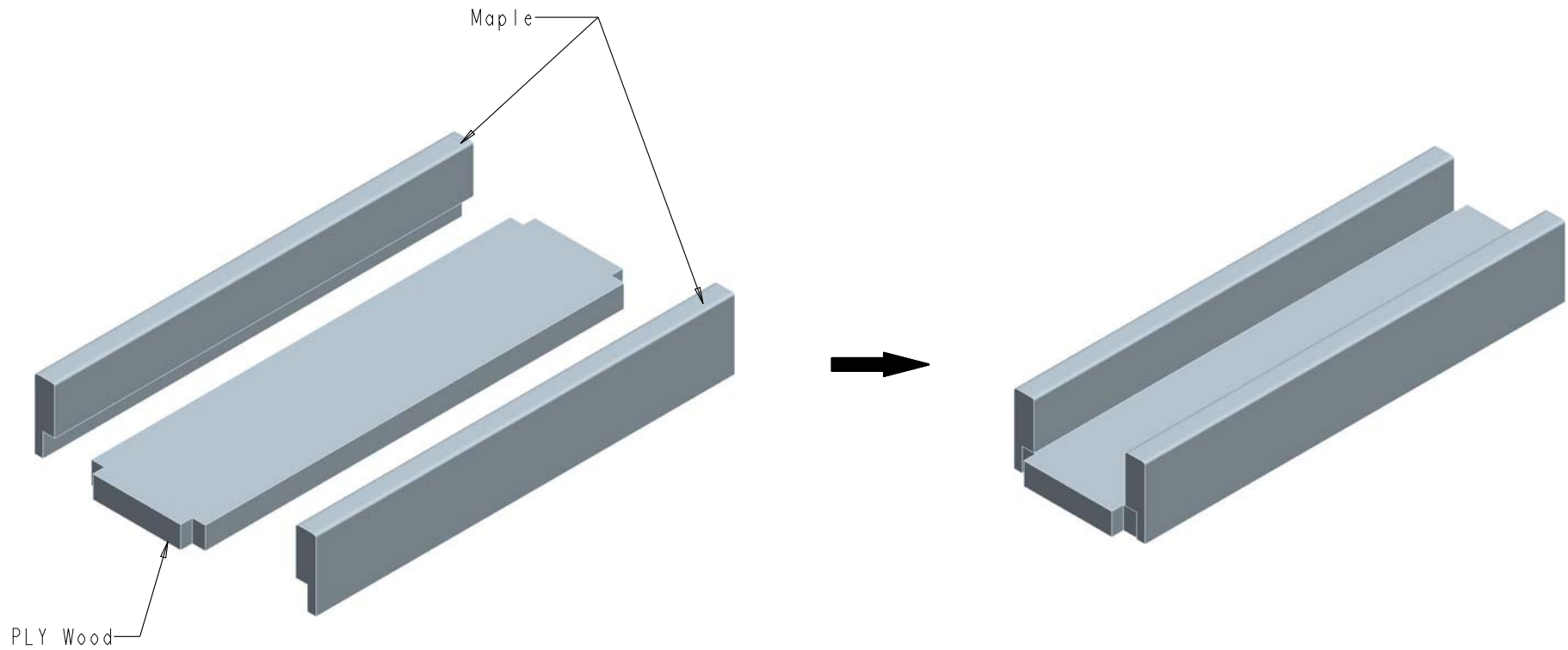

<b>HARDWARE</b> <b>HR</b> 4319 MARLENA ST. BOSSIER CITY, LA71111 <b>RESOURCES</b>	<b>ITEM#:</b> FIXED-SHELF-3IN		<b>MATERIAL:</b>		
	<b>FINISH:</b>		<b>WEIGHT:</b> 9		
<b>PROPRIETARY AND CONFIDENTIAL</b> THE INFORMATION CONTAINED IN THIS DRAWING IS THE SOLE PROPERTY OF HARDWARE RESOURCES INC. ANY REPRODUCTION IN PART OR AS A WHOLE WITHOUT THE WRITTEN PERMISSION OF HARDWARE RESOURCES INC. IS PROHIBITED	<b>TOLERANCE UNLESS OTHERWISE SPECIFIED:</b> X : MM ±0.20 X.X : MM ±0.10 X.XX : MM ±0.05 ANGULAR : ±0.5° DO NOT SCALE DRAWING		<b>UNIT:</b>	<b>DRAWN BY:</b> <i>alan.liu</i>	<b>DATE:</b>
	<b>SIZE:</b>	<b>CHECKED BY:</b>	<b>DATE:</b>		
	<b>APPROVED BY:</b>		<b>DATE:</b>		
	<b>PROJECTION:</b>				

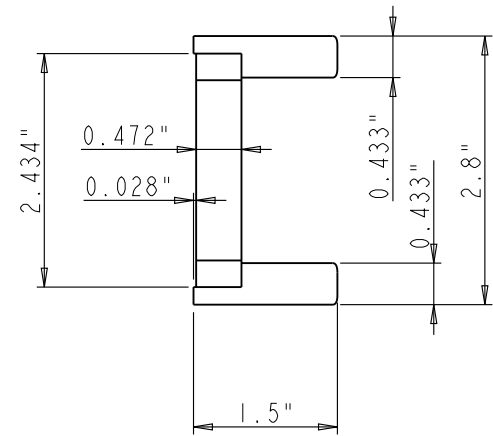
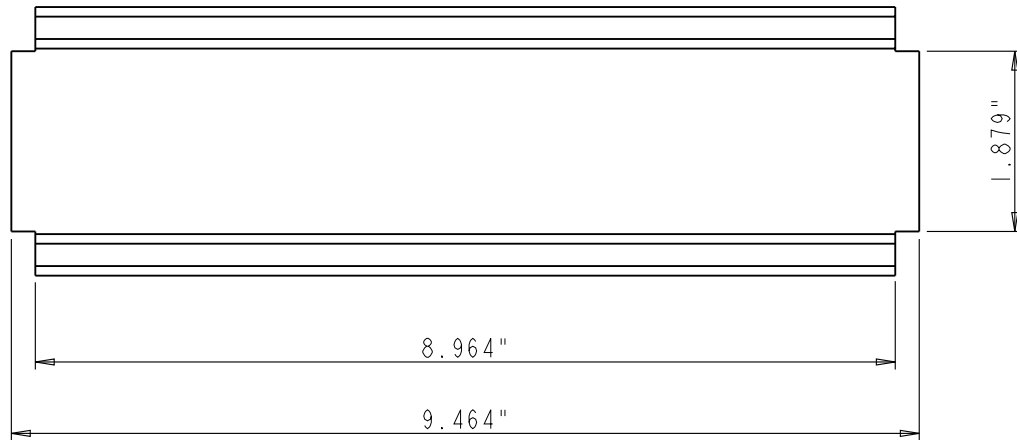

<b>HARDWARE</b> <b>HR</b> 4319 MARLENA ST. BOSSIER CITY, LA71111 <b>RESOURCES</b>	ITEM:	MATERIAL:	
	FIXED-SHELF-3IN		WEIGHT:
PROPRIETARY AND CONFIDENTIAL THE INFORMATION CONTAINED IN THIS DRAWING IS THE SOLE PROPERTY OF HARDWARE RESOURCES INC. ANY REPRODUCTION IN PART OR AS A WHOLE WITHOUT THE WRITTEN PERMISSION OF HARDWARE RESOURCES INC. IS PROHIBITED.	FINISH:	PROJECTION:	
TOLERANCE UNLESS OTHERWISE SPECIFIED: X : MM ±0.20 XX : MM ±0.10 XXX : MM ±0.05 ANGULAR: ±0.5° DO NOT SCALE DRAWING	UNIT:	DRAWN BY: <i>alan.liu</i>	DATE:
	SIZE:	CHECKED BY:	DATE:
		APPROVED BY:	DATE:



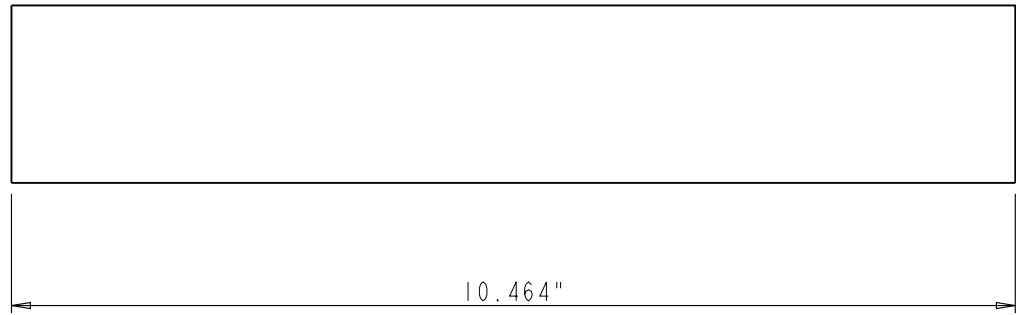
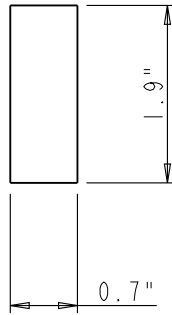

<b>HARDWARE</b> <b>HR</b> 4319 MARLENA ST. BOSSIER CITY, LA 71111 <b>RESOURCES</b>	<b>ITEM:</b> SLIDER-MOUNT-BOARD_MOVABLE		<b>MATERIAL:</b> PLY Wood		
	<b>FINISH:</b>		<b>WEIGHT:</b> g		
<u>PROPRIETARY AND CONFIDENTIAL</u> THE INFORMATION CONTAINED IN THIS DRAWING IS THE SOLE PROPERTY OF HARDWARE RESOURCES INC. ANY REPRODUCTION IN PART OR AS A WHOLE WITHOUT THE WRITTEN PERMISSION OF HARDWARE RESOURCES INC. IS PROHIBITED	<b>TOLERANCE UNLESS          OTHERWISE SPECIFIED:</b> X : MM ±0.20 X.X : MM ±0.10 X.XX : MM ±0.05 ANGULAR : ±0.5° DO NOT SCALE DRAWING		<b>UNIT:</b>	<b>DRAWN BY:</b> <i>alan.liu</i>	<b>DATE:</b>
	<b>SIZE:</b>		<b>CHECKED BY:</b>	<b>DATE:</b>	
	PAGE 00		<b>APPROVED BY:</b>		<b>DATE:</b>
	PROJECTION:				

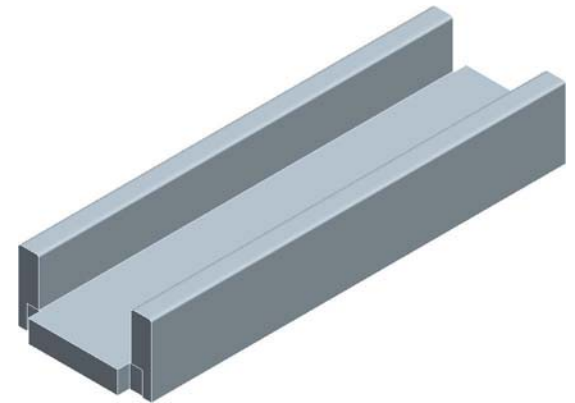
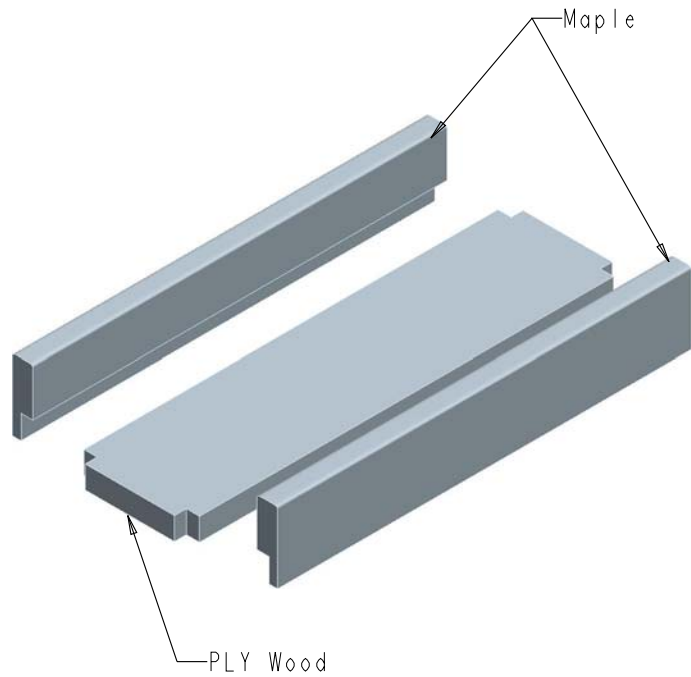

<b>HARDWARE</b> <b>HR</b> 4319 MARLENA ST. BOSSIER CITY, LA 71111 <b>RESOURCES</b>	<b>ITEM#:</b> REMOVABLE-SHELF-3IN		<b>MATERIAL:</b>	
	<b>FINISH:</b>		<b>WEIGHT:</b> 9	
<b>PROPRIETARY AND CONFIDENTIAL</b> THE INFORMATION CONTAINED IN THIS DRAWING IS THE SOLE PROPERTY OF HARDWARE RESOURCES INC. ANY REPRODUCTION IN PART OR AS A WHOLE WITHOUT THE WRITTEN PERMISSION OF HARDWARE RESOURCES INC. IS PROHIBITED.		<b>TOLERANCE UNLESS OTHERWISE SPECIFIED:</b> X : MM ±0.20 X.X : MM ±0.10 X.XX : MM ±0.05 ANGULAR : ±0.5° DO NOT SCALE DRAWING		<b>PROJECTION:</b> 
<b>UNIT:</b>		<b>DRAWN BY:</b> <i>alan.liu</i>		<b>DATE:</b>
<b>SIZE:</b>		<b>CHECKED BY:</b>		<b>DATE:</b>
PAGE 00		<b>APPROVED BY:</b>		<b>DATE:</b>

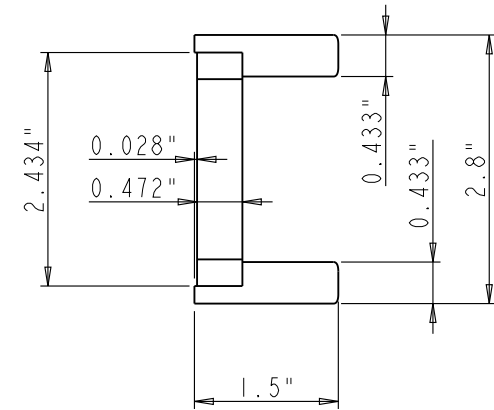
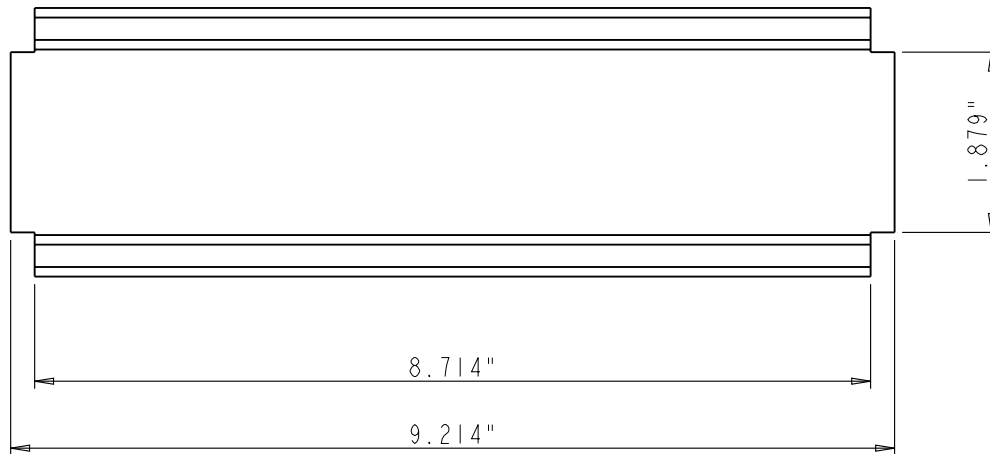

<b>HARDWARE</b> <b>HR</b> 4319 MARLENA ST. BOSSIER CITY, LA 71111 <b>RESOURCES</b>	<b>ITEM:</b> REMOVABLE-SHELF-31N		<b>MATERIAL:</b>		
	<b>FINISH:</b>		<b>WEIGHT:</b> 9		
<b>PROPRIETARY AND CONFIDENTIAL</b> THE INFORMATION CONTAINED IN THIS DRAWING IS THE SOLE PROPERTY OF HARDWARE RESOURCES INC. ANY REPRODUCTION IN PART OR AS A WHOLE WITHOUT THE WRITTEN PERMISSION OF HARDWARE RESOURCES INC. IS PROHIBITED	<b>TOLERANCE UNLESS          OTHERWISE SPECIFIED:</b> X : MM ±0.20 X.X : MM ±0.10 X.XX : MM ±0.05 ANGULAR: ±0.5° DO NOT SCALE DRAWING		<b>UNIT:</b>	<b>DRAWN BY:</b> <i>alan.liu</i>	<b>DATE:</b>
	<b>SIZE:</b>	<b>CHECKED BY:</b>	<b>APPROVED BY:</b>	<b>DATE:</b>	<b>DATE:</b>
	<b>PROJECTION:</b>				<b>DATE:</b>
	<b>PROJECTION:</b>				<b>DATE:</b>